

Submersible waste water pumps

Installation and operating instructions

Series: DVV

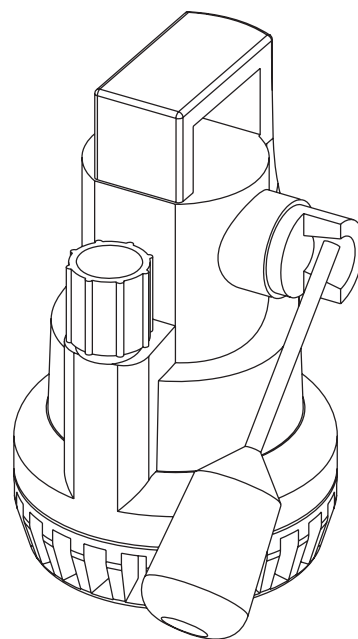
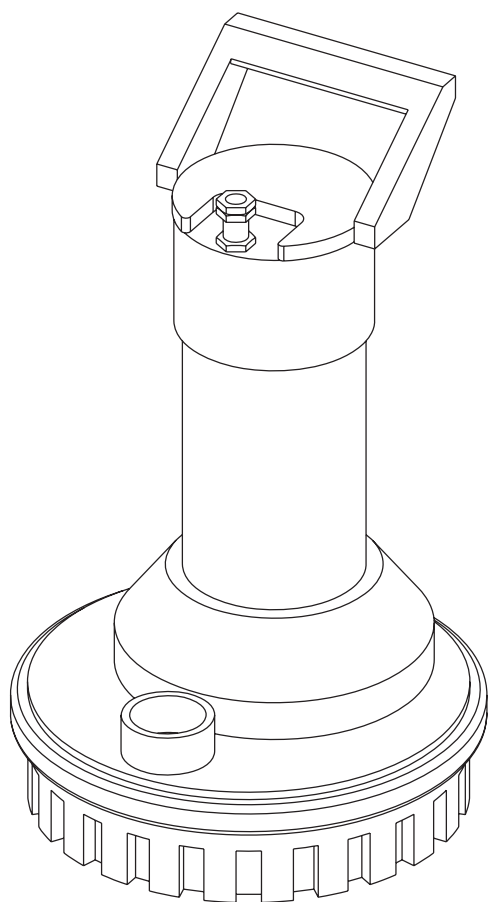

Table of Contents

1	Introduction	
1.1	Preface.....	3
1.2	Icons and symbols	3
2	Identification, service and technical support	
2.1	Obtaining data and information	4
2.2	Supplementary documentation	4
3	Warranty	
3.1	Terms of warranty	5
4	Safety and environment	
4.1	General	6
4.2	Users.....	6
4.3	Safety provisions.....	6
4.4	Safety precautions	6
4.5	Environmental aspects.....	7
5	Introduction	
5.1	General	8
5.2	Intended use	8
5.3	Working range.....	8
5.4	Operation	8
6	Transportation	
6.1	Transport.....	9
6.2	Storage.....	9
7	Installation	
7.1	Mechanical installation.....	10
7.2	Electrical installation	10
7.3	Commissioning	10
8	Operation	
8.1	Operation	12
9	Maintenance	
9.1	Introduction	13
9.2	Suction strainer DVV 7 disassembly/assembly.....	13
9.3	Taking out of operation for a long interval	13
2	10 Failures	
10.1	Failure table	14
11	Annexes	
11.1	Technical specifications	16
11.2	Electrical connections	16
11.3	EC Declaration of conformity	17

1 Introduction

1.1 Preface

This manual contains important information for reliable, proper and efficient operation. Compliance with the operating instructions is of vital importance to ensure reliability and a long service life of the product and to avoid any risks.

The first chapters contain information about this manual and safety in general. The following chapters provide information about normal use, installation, maintenance and repairs of the product. The annex contains the declaration(s) of conformity.

- Make yourself familiar with the content.
- Accurately follow the directions and instructions.
- Never change the sequence of the operations to be carried out.
- Keep this manual or a copy of it together with the logbook in a fixed place near the product which can be accessed by all personnel.



READ THE (SUPPLEMENTARY) DOCUMENTATION

Read the user and operating instructions.

1.2 Icons and symbols

In this manual and in all accompanying documentation the following icons and symbols are used.



WARNING

Danger of electric Voltage. Safety sign according to IEC 417 - 5036



WARNING

Operations or procedures, if carried out without caution, may cause personal injury or damage to the product.

General hazard sign according to ISO 7000-0434



ATTENTION

Is used to introduce safety instructions whose non-observance may lead to damage to the product and its functions.



ENVIRONMENTAL INSTRUCTION

Remarks with respect to the environment.

2 Identification, service and technical support

2.1 Obtaining data and information

You can identify the pump by the identification sticker that is found on the pump.

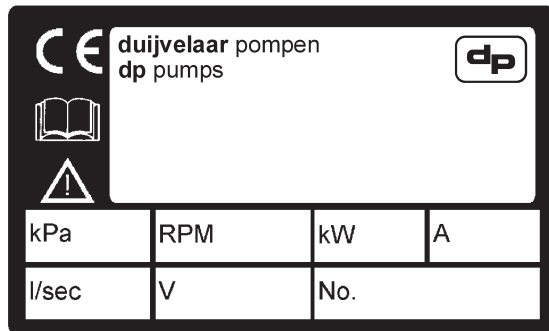

Indication	Meaning
DVV	Pump type
kPa	Nominal pressure
l/sec	Nominal capacity
RPM	Nominal speed
V	Nominal voltage
kW	Motor power
A	Nominal current
No.	Serial number

The following address data are available for service and technical support:

Table 1: Address service department

DP-Pumps Kalkovenweg 13 2401 LJ Alphen a/d Rijn The Netherlands	Tel: +31 172 488388 Fax: +31 172 468930 Internet: www.dp-pumps.com E-mail: dp@dp-pumps.com
--	--

2.2 Supplementary documentation

As well as this manual, the documentation given below is also available:

Document	Date/version	Code
General terms of delivery	10-1998	119 / 1998
Documentation	11- 2005	97004429

3 Warranty

3.1 Terms of warranty

The warranty period is settled by the terms of your contract or at least by the general terms and conditions of sales.



ATTENTION

Modifications or alterations of the product supplied are only permitted after consultation with the manufacturer. Original spare parts and accessories authorized by the manufacturer ensure safety. The use of other parts can invalidate any liability of the manufacturer for consequential damage.



ATTENTION

The warranty relating to the operating reliability and safety of the product supplied is only valid if the product is used in accordance with its designated use as described in the following sections of this manual. The limits stated in the data sheet must not be exceeded under any circumstances.

The warranty becomes invalid if one or more of the points below occur.

- The buyer makes modifications himself.
- The buyer carries out repairs himself or has these carried out by a third party.
- The product has been handled or maintained improperly.
- The product has non original DP-Pumps spare parts fitted.

DP-Pumps repairs defects under warranty when:

- They are caused by flaws in the design, the material or the production.
- They are reported within the warranty period.

Other terms of warranty have been included in the general terms of delivery, which are available upon request.

4 Safety and environment

4.1 General

This DP-Pumps product has been developed using state-of-the-art technology; it is manufactured with utmost care and subject to continuous quality control. DP-Pumps does not accept any liability for damage and injury caused by not observing the directions and instructions in this manual, or in cases of carelessness during the installation procedure, use and maintenance of the product.

Non-compliance with safety instructions can jeopardize the safety of personnel, the environment and the product itself. Non-compliance with these safety instructions will also lead to forfeiture of any and all rights to claims for damages.

For example, in particular non-compliance can result in:

- failure of important pump/system functions,
- failure of prescribed maintenance and servicing practices,
- injury to persons by electrical, mechanical and chemical effects,
- hazard of the environment due to leakage of hazardous substances,
- explosions.

Depending on specific activities, extra safety measures may be required. Contact DP-Pumps if a potential danger arises during use.



ATTENTION

The owner of the product is responsible for compliance with the local safety regulations and internal company guidelines.



ATTENTION

Not only must the general safety instructions laid down in this chapter on "Safety" be complied with, but also the safety instructions outlined under specific headings.

4.2 Users

All personnel involved in the operation, maintenance, inspection and installation of the product must be fully qualified to carry out the work involved and be aware

of all applicable responsibilities, authorisations and super visions. If the personnel in question is not already in possession of the required know-how, appropriate training and instruction must be provided. If required, the operator may commission the manufacturer / supplier to take care of such training. In addition, the operator is responsible for ensuring that the contents of the operating instructions are fully understood by the responsible personnel.

4.3 Safety provisions

The product has been designed with the greatest possible care. Original parts and accessories meet the safety regulations. Modifications in the construction or the use of non-original parts may lead to a safety risk.



ATTENTION

Make sure that the product operates within its working range. Only then the product performance is guaranteed.

4.3.1 Labels on the product

The icons, warnings and instructions applied to the product are part of the safety provisions. The labels may not be removed or covered. Labels must remain legible during the entire life of the product. Replace damaged labels immediately.

4.4 Safety precautions

4.4.1 During normal use

- Contact the local electricity company for questions about the power supply.
- Protect the parts that can become hot, making direct contact impossible.
- When applicable, always place undeformed coupling guards to protect the coupling, before putting the pump into use. Make sure that the coupling guards are never in contact with the rotating coupling.
- Always close the terminal box of the motor.
- Always close the control panel where applicable

4.4.2 During installation, maintenance and repair

Only authorised personnel may install, maintain and inspect the product and repair electrical components. Observe the local safety regulations.



WARNING
Always disconnect the energy supply to the product first, before installation, maintenance and repairs. Secure this disconnection.



WARNING
Surfaces of a pump can be hot after continuous operation.



WARNING
Make sure that no one can be near rotating components when starting a pump.



WARNING
Handle a pump with dangerous liquids with the utmost care. Avoid danger for persons or the environment when repairing leakages, draining liquids and venting. It is strongly recommended to place a leakage tray under the pump.



WARNING
Immediately following completion of the work, all safety-relevant and protective devices must be re-installed and / or re-activated.



WARNING
Please observe all instructions set out in the chapter "Commissioning/Start-up" before returning the product to service.

4.5 Environmental aspects

4.5.1 General

The products of DP-Pumps are designed to function in an environmentally friendly way during their entire lifetime. Therefore, when applicable, always use biodegradable lubricants for maintenance.



ENVIRONMENTAL INSTRUCTION
Always act according to the laws, by-laws regulations and instructions with respect to health, safety and the environment.

4.5.2 Dismantling

The owner is responsible for the dismantling and environmentally friendly disposal of the product.



ENVIRONMENTAL INSTRUCTION
Ask at the local government about the re-use or the environmentally friendly processing of discarded materials.

5 Introduction

5.1 General

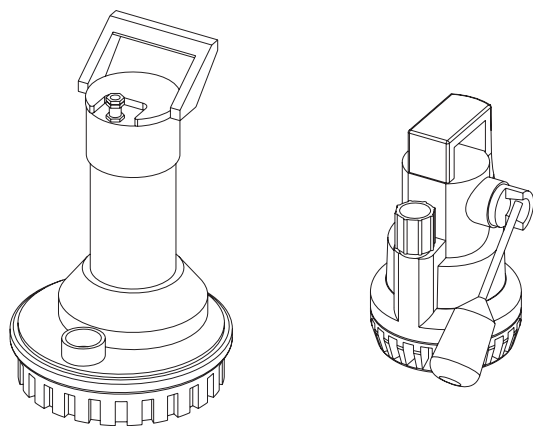

Figure 1: Submersible waste water pumps of the type DVV

Submersible waste water pumps of the type DVV are produced by DP-Pumps.

5.2 Intended use

The submersible waste water pumps of the DVV series are suitable for pumping sewage with small solid constituents, clean or slightly contaminated wastewater and rainwater within the specified working range (see "Working range").

Any other or further use of the pump is not in conformity with its intended use. DP-Pumps does not accept any liability for any damage or injury that results from this. The pump is produced in accordance with the current standards and guidelines. Use the pump only in a perfect technical state, in conformance with the intended use described below.

The *Intended use* as laid down in ISO 12100:2010 is the use for which the technical product is intended according to the specifications of the manufacturer. The use of the product has been described in the sales brochure and in the user manual. Always observe the instructions given in the user manual. When in doubt the product must be used as becomes evident from its construction, version and function.

5.3 Working range

The working range of the submersible waste water pumps in this series can be summarised as follows:

Table 2: Specification of the working range

DVV type	3 / 4	3IN/4IN/7/10/ 27IN	27
Maximum liquid temperature [°C]	35	40	50

Table 3: Specification of the working range

DVV type	3 / 7	10	27	3VD	4/7VD
Maximum granule size [mm]	10	11	12	24	35

Table 4: Specific applications

DVV type	Application area
3 / 4 / 7	Groundwater and rainwater from drains, crawling spaces, etc.
3IN/4IN/7IN/10IN/27IN	lightly aggressive substances. Sea water
7O/10O	Oil-containing water
27	Groundwater and rainwater from drains, tunnels, building pits, crawling spaces, etc.

5.4 Operation

The liquid is sucked in on the supply side under minimum pressure. The pump increases the pressure. The liquid leaves the pump on the delivery side.

Submersible waste water pumps that have been equipped with a build-in float are automatically switched on and off when reaching a high or low liquid level respectively.

6 Transportation

6.1 Transport



WARNING

Lift the pump, if necessary using a hoist and suitable slings. Attach the slings to the hoisting eyes on the packaging, where present.



WARNING

The pump must be hoisted according to the current hoist guidelines. Only qualified personnel are allowed to hoist the pump.

1. Transport the pump in the position as indicated on the pallet or packaging.
2. Make sure the pump is stable.
3. Observe the instructions on the packaging (if present).

6.2 Storage

6.2.1 Storage preparation

1. Spray clean the pump and the impeller in the pump housing well using clean water.
2. Store the pump in a dry and frost-proof location.
3. Put the pump in a vertical position.

6.2.2 Inspection during storage

1. Turn the impeller every three months. This will prevent sticking of the running seals.
2. Have the pump inspected before putting it into operation again after a storage period of 6 months or longer.

7 Installation

7.1 Mechanical installation



WARNING
Remove all cables and hoisting chains from the pump sump. Prevent thus that they can be sucked and damaged by the pump.



WARNING
Never allow the pump to drop from the feeder cable or delivery pipe.



WARNING
Do not use the pump in locations where there is freezing danger.

- Take the pump out of the packaging and check for any transportation damage.
- Check whether the delivery is complete based on the included Production Order Combination List. Contact DP-Pumps if the delivery is damaged and/or incomplete.
- Position and assemble the pump system on a suitable surface or suspend the pump using the grip.
- Position the pump on a paved surface when there is mud and sand.
- Check whether the pump impeller can turn freely.
- Make sure that the distance between the bottom and the supply (A) is at least the same as the free passage, see the technical information.
- Assemble, if required, a non-return valve in the delivery pipe to prevent liquid flowing back. This non-return valve is already installed in the pump with regard to the DVV 3/4.
- Assemble (if possible) a globe valve on the delivery side.
- Install the highest point of the delivery pipe above the drain pipes of the street (ground level) to make sure that a drain return flow is not possible.
- Install the cover strip over the turnbuckle of the bracket that is located between the suction strainer and the pump for the DVV7 and DVV10.

The direction of rotation of the pump is clockwise seen from the top of the pump (A). The reactive force

7.2 Electrical installation



WARNING
Only authorised personnel are allowed to make electrical connections to the motor in accordance with local regulations.

Electrical connections:

- Make sure that the motor specifications correspond with the power supply to which the pump motor is connected.
- Connect the pump using an interruptable connection (plug).

7.3 Commissioning



WARNING
The pump must not be switched on when it does not contain any liquid.



ATTENTION
The DVV 7 and DVV 10 have a vent hole between the stator case and pump housing. The DVV 7 K has a vent hole on the top of the sleeve. Liquid flows from these vent holes.

Proceed as follows when submersible waste water pumps are fitted with a float switch:
Adjust the cable length of the float in such a way that the collection container does not overflow. Make sure that the float has sufficient space to move and cannot get caught anywhere.

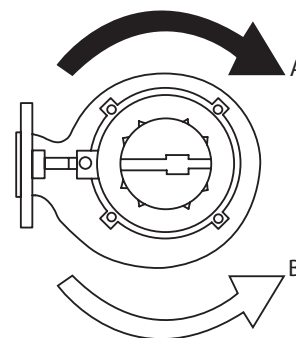

will cause a shock movement in the opposite direction (B) when started.

7.3.1 Setting of the DVV 3 & 4 switching level

The switching level (on switching point) set by the factory can be changed by switching disc C.

- Check the operation of the pump before it is connected to the mains. Move the float up and down several times. You should hear a light clicking noise when switching on and off.
- Again connect the pump to the mains

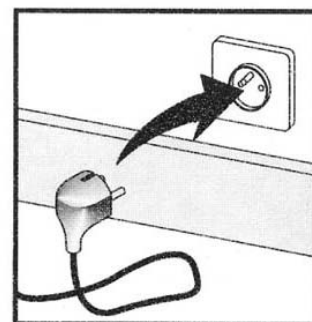
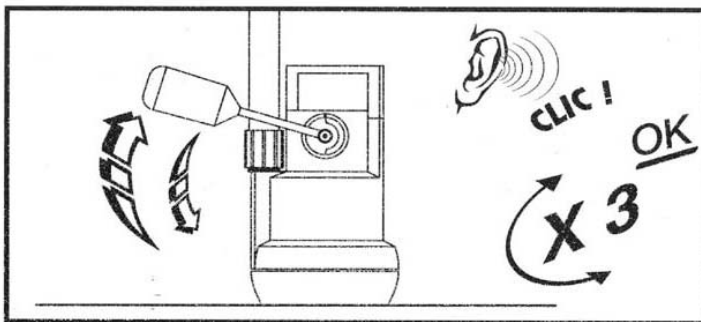
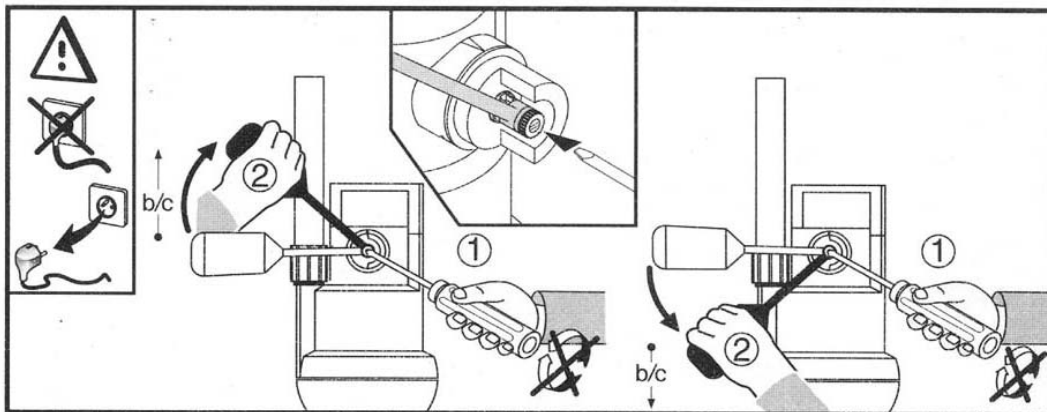
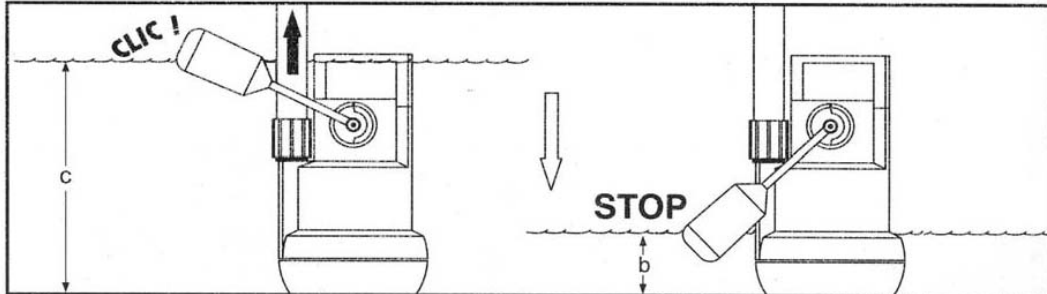

8 Operation

8.1 Operation

Pump type	operation
xxx-W	pump with earthed plug
xxx-WS	switch on/off the pump automatically through the float switch
xxx-S	MANUAL - switch on the pump manually 0 - pump off Auto - pump automatically on/off through the float switch
xxx-	pump with free cable end

9 Maintenance

9.1 Introduction



WARNING

Observe the general safety precautions for installation, maintenance and repair.

Regular maintenance is necessary for correct operation of the installation. For maintenance of the installation, please contact your supplier. A draft maintenance contract is available upon request.

9.2 Suction strainer DVV 7 disassembly/assembly

To clean the impeller and suction strainer:

1. Remove the cover strip of the turnbuckle.
2. Remove the clamping bracket.
3. The suction strainer can now be removed and cleaned.
4. The pump housing can now be removed and cleaned.
5. Assemble everything in the inverse order.
Turnbuckle torque = 6 Nm

9.3 Taking out of operation for a long interval

Turn the impeller every three months. This will prevent seals from sticking.

Protect the pump against freezing if there is a risk of frost. Proceed as follows:

1. Close all globe valves.
2. Remove the pump from the drain.
3. Make sure the pump is cleaned correctly by spraying with a powerful water jet.
4. Store the pump in a dry and frost-proof location.

10 Failures

10.1 Failure table



WARNING

Take the general safety measures for the installation, maintenance and repair into consideration.

Problem	Possible cause	Possible solution	Checkpoints
The pump will not start	No voltage on the terminal clamps	Check the power supply	<ul style="list-style-type: none"> • Circuit • Main switch • Hand-0-Aut switch • Fuses
		Check the motor safety relay	<ul style="list-style-type: none"> • Earth leakage switch • Protective relay • Motor temperature • Water feeler (option)
		Check the start signal	<ul style="list-style-type: none"> • Medium level • Level switching • Start-stop change • Switch box
	Motor failures	Check the motor	<ul style="list-style-type: none"> • Insulation test • Phase resistance • Thermistor
The pump does not stop	No stop signal	Check level switching	<ul style="list-style-type: none"> • Level switching • Switch box
	Air in the pump housing	Temporarily remove the pump from the coupling	<ul style="list-style-type: none"> • Pump switching level
Capacity too high	No counterpressure, free outflow	Increase the counterpressure	<ul style="list-style-type: none"> • Pipe loss calculation
Capacity too low	incorrect direction of rotation	exchange two phases	
	Air in the pump housing	Temporarily remove the pump from the coupling	<ul style="list-style-type: none"> • pump on switching level
	Blockage	clean the pump and the pipework	

Problem	Possible cause	Possible solution	Checkpoints
The pump starts and stops quickly after each other	Incorrect start/stop signal	Check the level switches	<ul style="list-style-type: none"> • Level switching • Adjusting switches
	Power supply is unstable	Check the power supply	<ul style="list-style-type: none"> • Circuit • Undervoltage • 3-phase available? • Adjustment of the motor protection
	The motor is overloaded	Check the motor protection and the pump	<ul style="list-style-type: none"> • Direction of rotation • Impeller blockage • Motor protection reset position
	The motor has overheated	Check the cooling	<ul style="list-style-type: none"> • Insulation test
Thermal protection is continuously activated	Pump current too high	Check the power supply	<ul style="list-style-type: none"> • Fuses • Undervoltage
	Thermal protection is set to a value that is too low	Compare the settings with the settings on the identification label	
	Capacity too high	Increase the counterpressure	
	Direction of rotation incorrect	Exchange two phases	

11 Annexes

11.1 Technical specifications

DVV type	Power [kW]	Voltage [V]	In [A]	starts/u	V oil in oil chamber [l]
32 W(S)(IN)	0.15	1 x 230	1.4		
42 WS	0.17	1 x 230	1.6		
43 WS	0.3	1 x 230	2.8		
34 WS VD	0.4	1 x 230	2.8		
34 W (S) (IN)	0.4	1 x 230	3.6		
44 WS	0.4	1 x 230	3.6		
76 W (S) (IN) (O) (K) (VD)	0.55	1 x 230	4.1	30	0.075
76 (S) (IN) (O) (K) (VD)	0.55	3 x 400	1.7	30	0.075
78 W (S) (IN) (O) (K)	0.75	1 x 230	5.5	30	0.075
78 (S) (IN) (O) (K)	0.75	3 x 400	1.9	30	0.075
711 W (S) (IN) (O) (K) (VD)	1.1	1 x 230	6.55	30	0.075
711 (S) (IN) (O) (K) (VD)	1.1	3 x 400	2.5	30	0.075
715 W (S) (IN) (O) (K)	1.5	1 x 230	8.95	30	0.075
715 (S) (IN) (O) (K)	1.5	3 x 400	3.6	30	0.075
722 (S) (IN) (O) (K) (VD)	2.2	3 x 400	4.8	30	0.075
1022 (S) (IN) (O)	2.2	3 x 400	4.8	30	0.075
2740 (S) (IN)	4	3 x 400	8.5	20	0.8
2775 (S) (IN)	7.5	400/692	15.4	20	1

11.2 Electrical connections



ATTENTION

The bi-metal switch (connection 21-22) of the pump is suitable for switching 250 V AC at 1.6 A

Table 5: Cable coding

		DVV 7 / 10	DVV 2775
L1	U1	1	Cable 1 black
L2	V1	2	Cable 1 brown
L3	W1	3	Cable 1 blue
L2	U2		Cable 2 4
L3	V2		Cable 2 3
L1	W2		Cable 2 5
Bi-metal	21	4	Cable 2 1
	22	5	Cable 2 2
Earthing	PE	green/yellow	green/yellow

11.3 EC Declaration of conformity

Undersigned:

DP-Pumps

Kalkovenweg 13

2401 LJ Alphen aan den Rijn, The Netherlands

Tel: +31 172 48 83 88

Fax: +31 172 46 89 30

The manufacturer herewith declares that the products:

Product: Submersible waste water pumps

Type: DVV

- is in conformity with the provisions of the following directives as amended from time to time:
 - Machinery Directive 2006/42/EC
 - Construction Product Directive 89/106/EEC

The manufacturer also declares that

- the following harmonised international standards have been applied:
 - ISO 12100
 - EN 809/A1
 - EN 60034-1, EN 60034-5/A1
 - EN 60335-1/A1, EN 60335-2-41/A1

If the pump is used as a stand alone installation, it is subject to this declaration of conformity.

If the pump is built in an appliance or is assembled together with other equipment in certain installations, then it should not be put into operation until a declaration has been given with respect to the appliance concerned that it complies with the directives listed above.



Alphen aan den Rijn,
20-06-2014

Responsible person:

W. Ouwehand, technical director



dp pumps

dp pumps
P.O. Box 28
2400 AA Alphen aan den Rijn
The Netherlands

t +31 172 48 83 88
f +31 172 46 89 30

dp@dp-pumps.com
www.dp-pumps.com

06/2014

BE00000303-A
Can be changed without prior notice
Original instructions

